

INSTRUCTION SHEET: MATCH DRILLING / STRAIGHTENING YOUR BENT GEAR LEGS

Please note: If you do not follow these simple instructions, you lose. If you follow these instructions to the letter, you win, and the job gets done in an orderly time frame.

1. Get a piece of plywood from Home Depot or wherever, a couple of 2 x 2's and build a box to fit your gear leg. (see drawing below)
2. Print and fill out the order form below with correct addresses, home & shipping addresses, phone #'s where you can be reached, along with specific instructions.
3. Enclose this information INSIDE the box, in a zip lock baggie you've stolen from your wife's kitchen. Be sure the gear leg is secured properly. (we drill small holes and fasten the gear leg to the box bottom with wire ties so it can't move around.) Then pack it with paper.
4. Write your name and address on the box top with a permanent marker, so we don't lose it in our shop.
5. Send it to us UPS. We will use this magnificent box to ship the gear leg back to you.
6. Enclose a check for \$100.00, we will refund any overpayment, or bill you for underpayment.
7. Secure this beautiful box with screws. Note: You build airplanes. This should be easy for you.

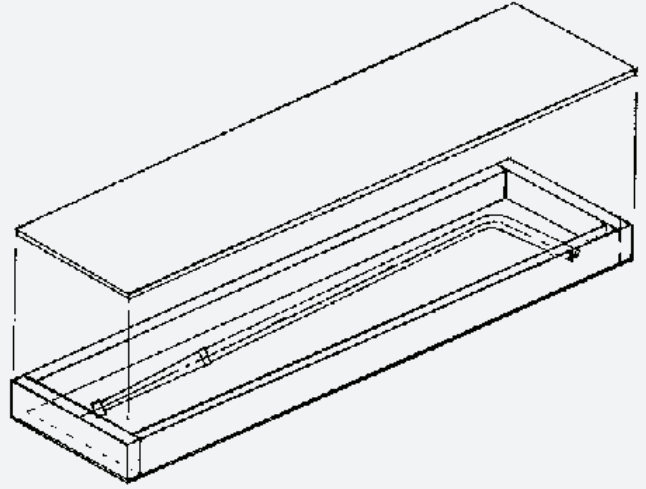

Your Contact Information

Name: _____

Address: _____

City, State, Zip: _____

Contact Phone: _____

Email: _____

Landing Gear Type: _____

Mains _____ Nose Wheel Gear _____ Tailspring _____

Ship To Address (if different than contact info)

Name: _____

Address: _____

City, State, Zip: _____

Contact Phone: _____

Special Instructions To Langaire: